

4.0

HYDRAULIC ACCESSORIES

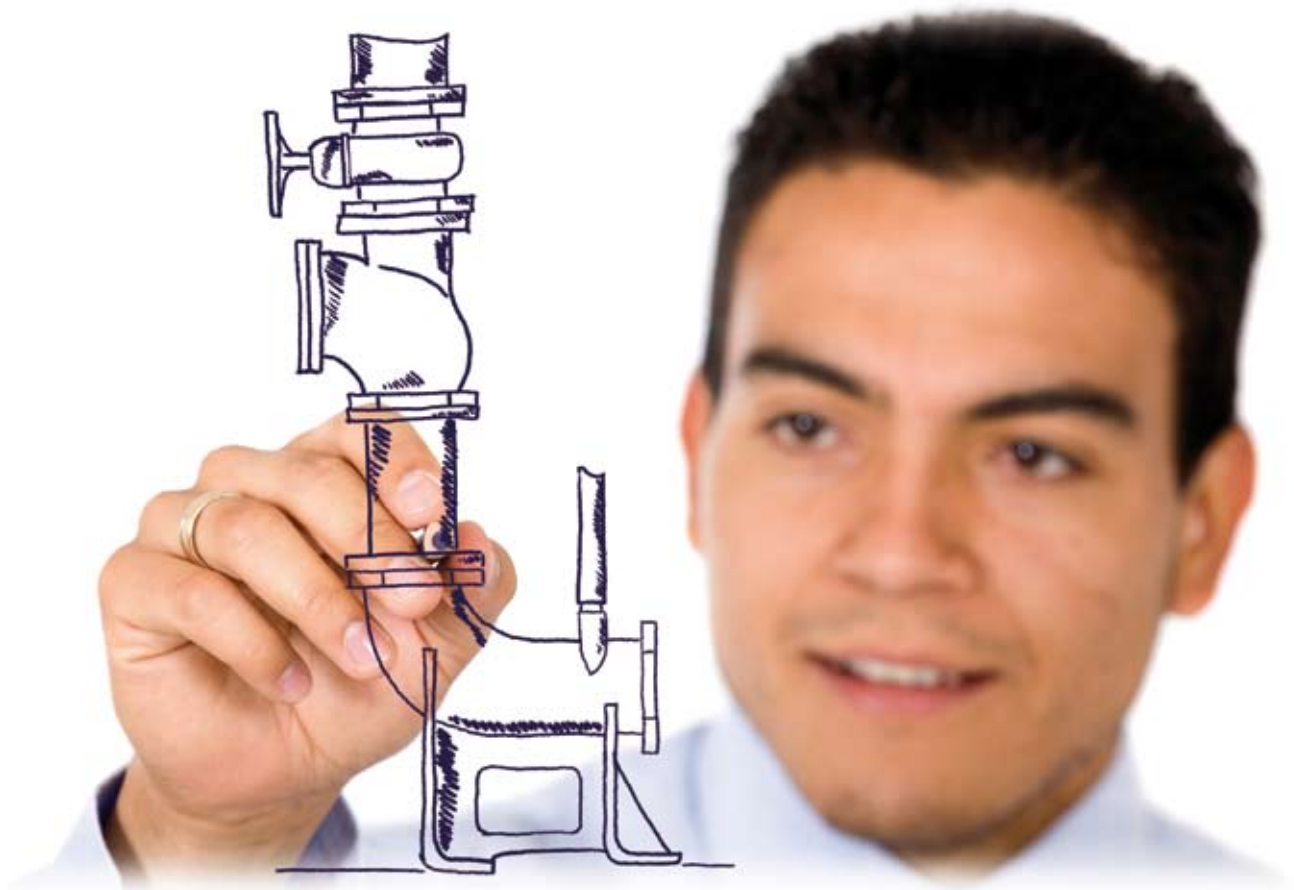

4.1 COUPLING DEVICES AND BASE PLATES

Coupling devices are essential accessories for making a reversible hydraulic connection between the pump and the outlet piping. This system allows the pump to be brought to the surface and then quickly reconnected, with no need to drain the tank, often an expensive operation involving lengthy plant stoppages. Perfect coupling between flange and device is ensured on all units in the Zenit range by means of a rubber seal. In addition, all bottom devices are designed with two guide pipes for trouble-free perfect alignment during coupling.

The external coupling device (DAC E), the only accessory of its type, can also be applied and used on existing plants. The unusual shape of the accessory allows the unpleasant and laborious task of tank draining to be avoided even during the installation stages.

The Zenit bottom coupling devices can have horizontal or vertical outlets in order to better adapt to the customer's needs.

All cast iron coupling devices are designed to receive 2 guide pipes which can accompany the pump into its working position without undesired twisting. Furthermore, a PATENTED system simplifies pump release and reduces the mechanical stresses on the guide pipes, even after an extended period of time immersed in the wastewater.

There is also a special stainless steel device that is indicated for the installation with pumps from the DRY series when acids or sea water are present.

Another special feature of the Zenit vertical coupling systems is that they are designed to keep the pump's intake port at an ideal distance without the need for creating a step.

They therefore provide a considerable savings in terms of time and the costs involved in the building of the collection tanks as well as easy replacement in pre-existing plants.

The DAC V vertical bottom coupling device can be coupled to a special 2" ball valve.

Thanks to the special breather valve incorporated into the DAC structure, any air pockets that may form during the summer, for example, when the water level in the well drops below the priming threshold, are expelled allowing the electric pump to operate regularly.

The image below shows the previously described version.

This accessory's reduced size allows for easy use in small dimension wells.

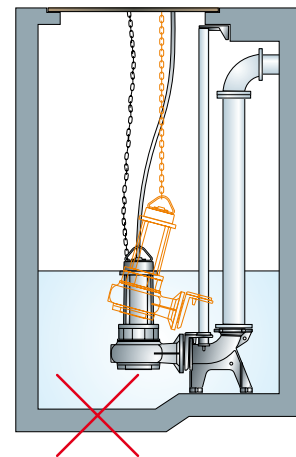
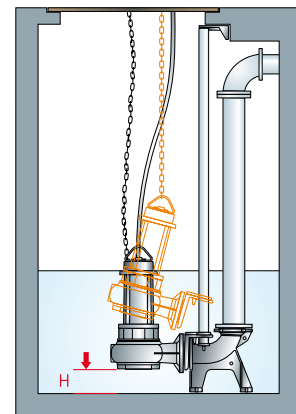
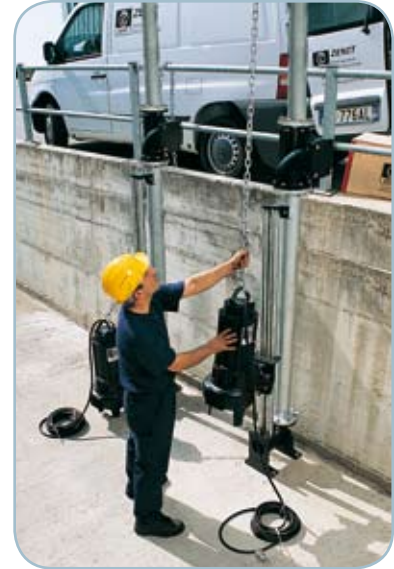

DAC E (GAS 2")

External coupling devices



General characteristics

- fixed structure in GJL-250 cast iron - movable structure in GJS-600-3
- epoxy-vinyl paint
- seals in NBR rubber
- full free passage
- fixing to tank walls by means of DN50 PN10 flange or 2" GAS thread
- with a suitable male/female reduction adapter the accessory can also be used with GAS 1 1/4" and GAS 1 1/2" delivery pumps

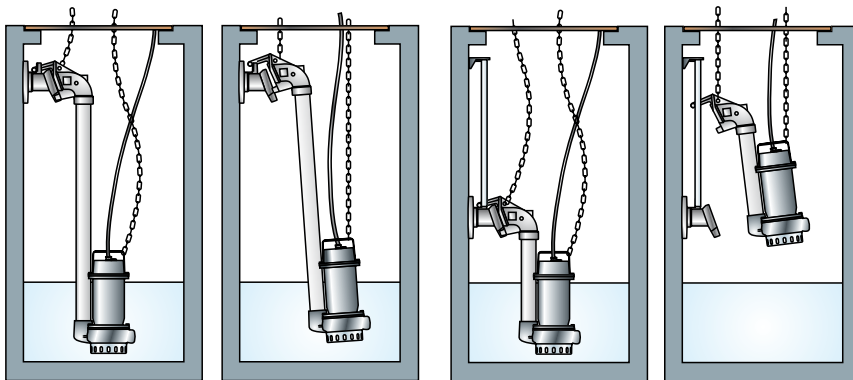

In installations in which the DAC-E needs to be fastened far from the well cover, two guide pipes (3/4") may be used, which are helpful for accompanying the electric pump until it is perfectly coupled.

Models

DAC -E G50/50H Inlet GAS 2", outlet GAS 2" and flange DN50 PN10

Overall dimensions and weights

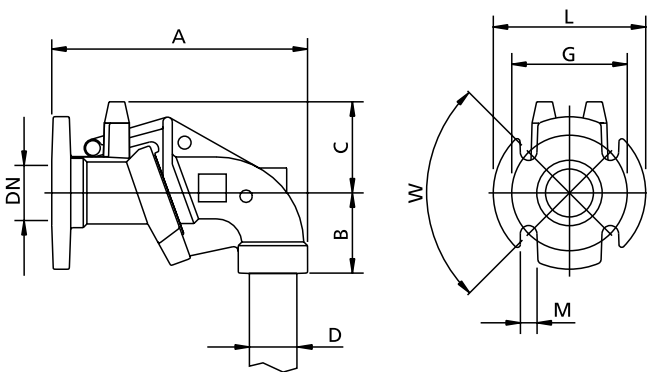

	A	B	C	D	DN	G	L	M	W	kg
DAC -E G50/50H	280	90	100	G 2"	G 2"	125	165	18	90°	8

Measurements in mm

Packaging dimension

	A	B	C
DAC -E G50/50H	385	225	245

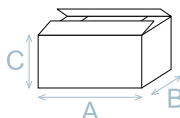

DAC V (1 1/2" - 2" and DN32 PN6 - DN50 PN10)

Bottom coupling devices with vertical outlet

General characteristics

- structure in GJL-250 cast iron
- seal in NBR rubber
- epoxy-vinyl paint
- full free passage
- complete with fitting for connection to polyethylene tube (diameter 63 mm)
- threaded outlet GAS 2" and GAS 2 1/2"
- complete with pipe guide and sliding flange with stainless steel fasteners
- allows the pump intake port to be kept at optimal height, meaning there is no need to provide a step in the bottom of the tank
- version with ball valve directly on the delivery port. This model comes with an incorporated breather valve for air venting



Models

DAC-N G40V/G50-65V Inlet for vertical delivery pumps GAS 1 1/2", outlet GAS 2" - 2 1/2"
 DAC-N G50V/G50-65V Inlet for vertical delivery pumps GAS 2", outlet GAS 2" - 2 1/2"
 Both of the accessories have a fitting for a PE 63 tube (GTP) or a ball check valve (VAP) + breather valve

DAC-N 32-50/G50-65V Inlet DN32 PN6 and DN50 PN10, outlet GAS 2" and GAS 2 1/2"
 The accessory comes supplied with a fitting for a PE 63 (GTP) tube

DAC-N 32-50/G50V+VAP Inlet DN32 PN6 and DN50 PN10, outlet GAS 2" (valve outlet diameter)
 The accessory comes supplied with a 2" ball valve
 For correct operation, the DAC structure must have an automatic air release valve.

Overall dimensions and weights

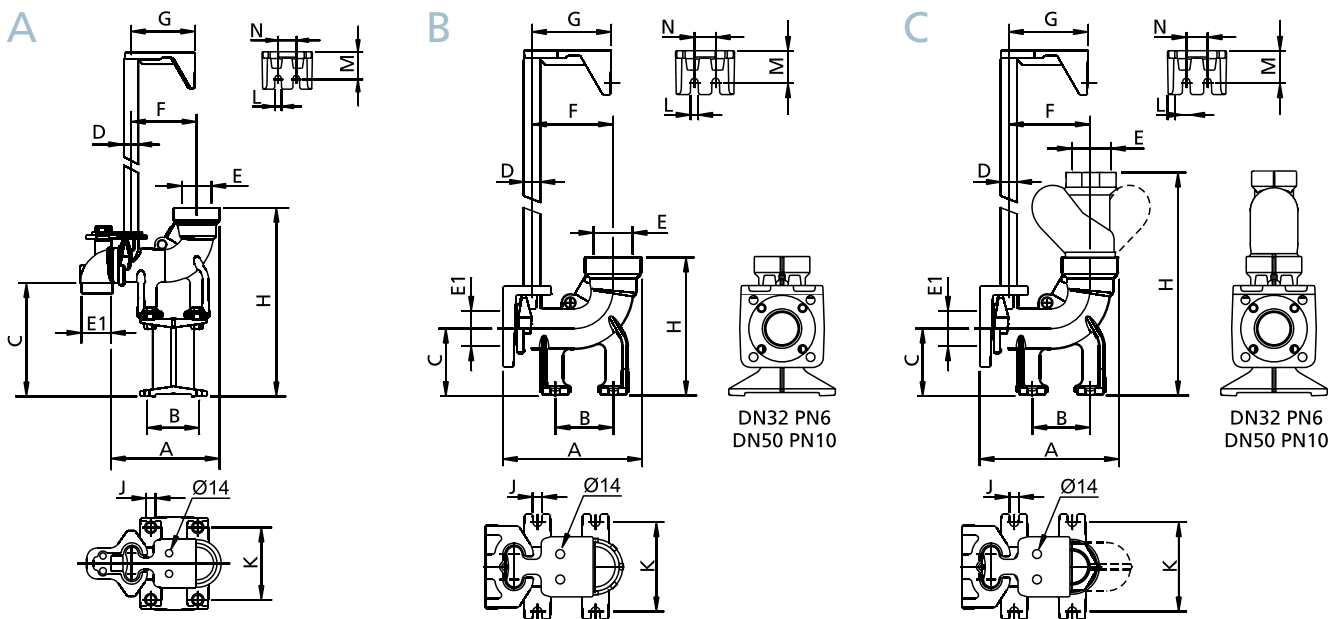

A	A	B	C	D	E	E1	F	G	H	J	K	L	M	N	Kg
DAC-N G40V/G50-65V	200	90	165	3/4"	G 2"-G 2 1/2"	G 1 1/2"	130	125	360	14	140	12	50	35	11
DAC-N G50V/G50-65V	200	90	220	3/4"	G 2"-G 2 1/2"	G 2"	130	125	360	14	140	12	50	35	11

B	A	B	C	D	E	E1	F	G	H	J	K	L	M	N	Kg
DAC-N 32-50/G50-65V	220	90	105	3/4"	G 2"-G 2 1/2"	50	130	125	215	14	140	12	50	35	8

C	A	B	C	D	E	E1	F	G	H	J	K	L	M	N	Kg
DAC-N 32-50/G50V+VAP	220	90	105	3/4"	G 2"	50	130	125	355	14	140	12	50	35	9

Measurements in mm

DAC V (DN65÷DN300)

Bottom coupling devices with vertical outlet

General characteristics

- structure in GJL-250 cast iron
- seal in NBR rubber
- epoxy-vinyl paint
- full free passage
- complete with pipe guide and sliding flange with stainless steel fasteners
- allows the pump intake port to be kept at optimal height, meaning there is no need to provide a step in the bottom of the tank
- a PATENTED system simplifies pump release and reduces the mechanical stresses on the guide pipes



Models

DAC-N 65/65V	Inlet DN65 PN10-16, outlet DN65 PN10-16
DAC-N 80/80V	Inlet DN80 PN10, outlet DN80 PN10-16
DAC-N 100/100V	Inlet DN100 PN10-16, outlet DN100 PN10-16
DAC-N 150/200V	Inlet DN150 PN10-16, outlet DN200 PN10
DAC-N 200/250V	Inlet DN200 PN10, outlet DN250 PN10
DAC-N 250/300V	Inlet DN250 PN10, outlet DN300 PN10
DAC-N 300/350V	Inlet DN300 PN10, outlet DN350 PN10

Overall dimensions and weights

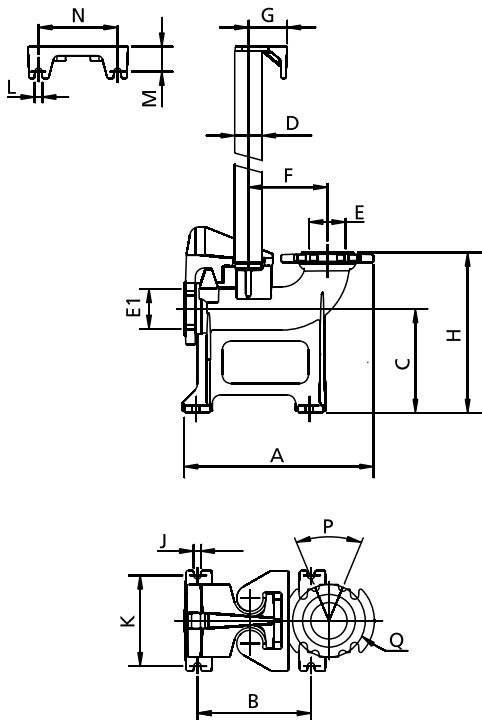

Packaging dimension

	A	B	C
DAC-N G40V/G50-65V	385	225	245
DAC-N G50V/G50-65V	385	225	245
DAC-N 32-50/G50-65V	385	225	245
DAC-N 32-50/G50V+VAP	385	225	245
DAC-N 65/65V	475	375	240
DAC-N 80/80V	475	375	240
DAC-N 100/100V	475	375	240

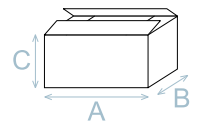

	A	B	C	D	E	E1	F	G	H	J	K	L	M	N	P	Q	Kg
DAC-N 65/65V	400	250	240	2"	65	65	170	85	355	16	200	16	55	175	90	145	26
DAC-N 80/80V	420	250	230	2"	80	80	175	85	355	16	200	16	55	175	45	160	28
DAC-N 100/100V	450	250	220	2"	100	100	195	85	355	16	200	16	55	175	45	180	31
DAC-N 150/200V	625	280	410	2"	200	150	305	150	600	24	250	14	50	100	45	295	117
DAC-N 200/250V	700	500	370	2"	250	200	355	150	600	24	250	14	50	100	30	350	149
DAC-N 250/300V	810	500	525	2"	300	250	430	150	805	24	250	14	50	100	30	400	192
DAC-N 300/350V	955	500	495	3"	350	300	445	135	850	24	460	20	75	180	22.5	460	293

Measurements in mm

DAC H (DN32 PN6 - DN50 PN10) (DN65÷DN250)

Bottom coupling devices with horizontal outlet

General characteristics

- structure in GJL-250 cast iron
- seal in NBR rubber
- epoxy-vinyl paint
- full free passage
- DN32-50 models complete with pipe guide, sliding flange (including stainless steel fasteners) and 2" GAS threaded bend in stainless steel
- DN65÷250 models complete with pipe guide and sliding flange with stainless steel fasteners
- a PATENTED system simplifies pump release and reduces the mechanical stresses on the guide pipes



Models

- DAC-N 32-50/G50H Inlet DN32 PN6 and DN50 PN10, horizontal outlet GAS 2"
- DAC-N 65/65H Inlet DN65 PN10-16, outlet DN65 PN10-16
- DAC-N 80/80H Inlet DN80 PN10, outlet DN80 PN10-16
- DAC-N 100/100H Inlet DN100 PN10-16, outlet DN100 PN10-16
- DAC-N 150/150H Inlet DN150 PN10-16, outlet DN150 PN10-16
- DAC-N 200/200H Inlet DN200 PN10, outlet DN200 PN10
- DAC-N 250/250H Inlet DN250 PN10, outlet DN250 PN10

Overall dimensions and weights

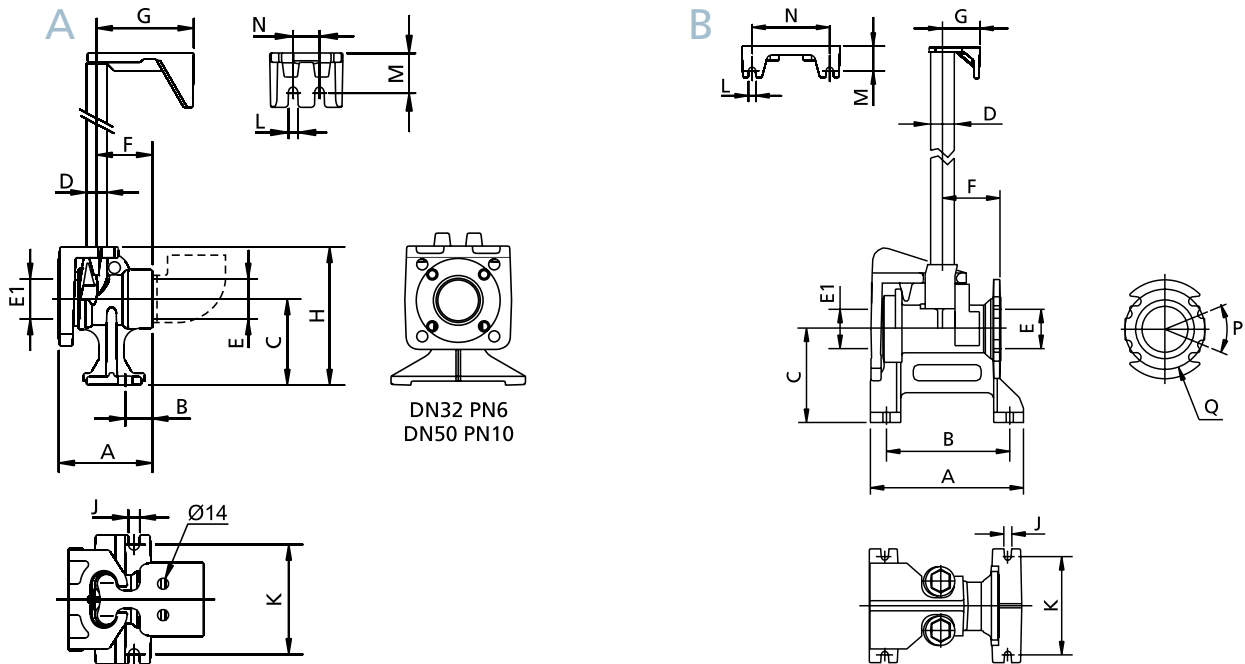

A	A	B	C	D	E1	E	F	G	J	K	L	M	N	kg		
DAC-N 32-50/G50H	120	35	110	3/4"	50	G 2"	70	125	14	140	12	50	35	6.5		
B	A	B	C	D	E1	E2	F	G	J	K	L	M	N	P	Q	kg
DAC-N 65/65H	310	250	180	2"	65	65	120	85	16	200	16	55	174	90	145	35
DAC-N 80/80H	310	250	190	2"	80	80	120	85	16	200	16	55	174	45	160	35
DAC-N 100/100H	320	250	190	2"	100	100	130	85	16	200	16	55	174	45	180	39
DAC-N 150/150H	405	250	240	2"	150	150	160	150	24	250	14	50	100	45	240	70
DAC-N 200/200H	405	250	240	2"	200	200	170	150	24	250	14	50	100	45	295	87
DAC-N 250/250H	540	400	375	2"	250	250	265	150	24	250	14	50	100	30	350	120

Measurements in mm

DAC X (DN65÷DN100)

Stainless steel bottom coupling devices

General characteristics

- structure and flange in AISI 316 stainless steel
- seal in NBR
- full free passage
- recommended for installations with corrosive or saline liquids

Models

- DACX-N 65/65V Inlet DN65 PN10, outlet DN65 PN10-16
- DACX-N 80/80V Inlet DN80 PN10, outlet DN80 PN10-16
- DACX-N 100/100V Inlet DN100 PN10, outlet DN100 PN10-16



The DAC X bottom coupling devices are specially indicated for the used with DRY type pumps and allow you to obtain a system that is completely in stainless steel and resistant to chemically aggressive liquids.

Overall dimensions and weights

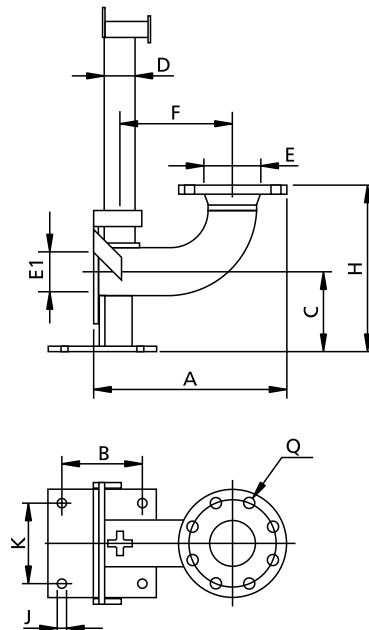

	A	B	C	D	E	E1	F	H	J	K	Q	Kg
DACX-N 65/65V	320	120	170	50	65	65	170	300	13	120	145	15
DACX-N 80/80V	335	120	150	50	80	80	185	310	14	120	160	17
DACX-N 100/100V	390	120	185	50	100	100	220	380	13	120	180	19.2

Measurements in mm

ACCESSORIES FOR COUPLING DEVICES

A wide range of accessories for coupling devices allow any type of plant to be optimized and reduce installation times.

KAF

Sliding flange for:

- OXY50 (KAF 32-50)
- DAC H (check the dimensions of KAF for correct coupling)
- DAC V (check the dimensions of KAF for correct coupling)

This accessory can be coupled to Flygt devices

(pay special attention to the diameter of the guide pipes, letter C in the table)

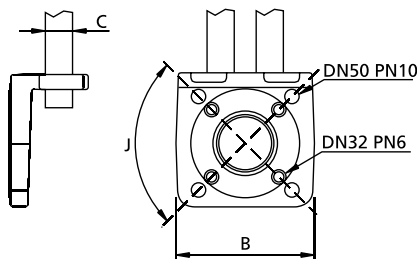

	Flange	B	C	D	J
KAF 32-50	32 PN6-50 PN10	130	3/4"	M12-M16	90°

Measurements in mm

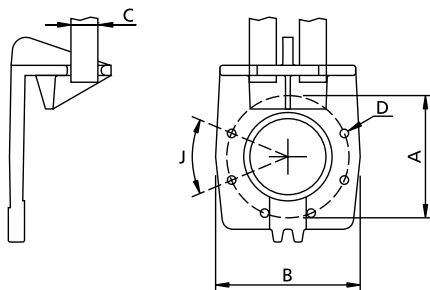

	A	B	C	D	J
KAF 65	145	160	2"	M16	90°
KAF 80	160	160	2"	M16	90°
KAF 100	180	210	2"	M16	45°
KAF 150	240	285	2"	M20	45°
KAF 200	295	345	2"	M20	45°
KAF 250	350	400	2"	M20	30°

Measurements in mm

- Supplied with NBR rubber seal and stainless steel fasteners
- Contact the Zenit Sales Department for compatibility with other manufacturers

KGP

Hook for Zenit foot ideal for coupling with DAC of 300 mm diameter and above, with double 3" guide pipes

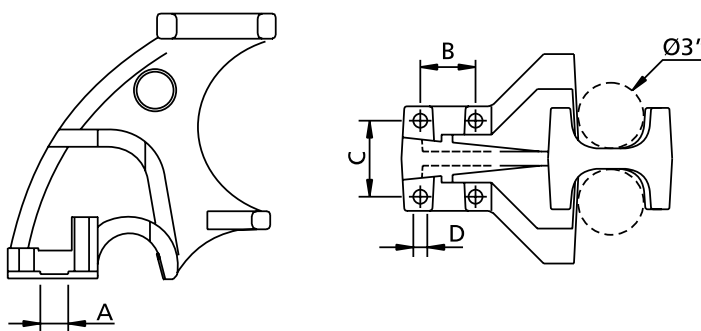

This accessory can be used with any Zenit electric pump (check for the presence of the overall dimensions of the individual pumps on the drawing), allowing it to be coupled to DACs with 3" guide pipes and DAC Flygts with the same guide pipes.

	A	B	C	D	Kg
KGP-D	40	79	109	21	40

Measurements in mm

BASE PLATES

Base plates for FREE installation allow the pump to be positioned in the tank quickly and ensure a high level of stability thanks to the large contact surface. Made of cast iron (GJS-600.3) or galvanized steel. Complete with stainless steel fasteners.

CAST IRON BASE PLATES

9024.010



Cast iron 3 spoke base plate for free installation. Suitable for the following models:

- DGO 150-200/2/G65V-65-80
- DGF 150-200/2/G65V-65-80

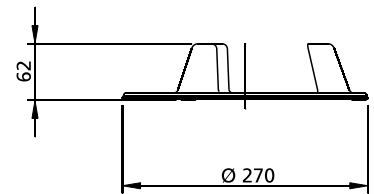

9024.006



Cast iron 3 spoke base plate for free installation. Suitable for the following models:

- DGI 100/4/80
- DGF 100/4/65-80
- DGN 250-300/2/G65V-65-80
- DGN 300-400-550/2/65-80
- DRN 250-300/2/65-80
- DRN 400-550/2/65-80
- MAI 100/4/80
- MAN 250-300/2/G65V-65-80
- MAN 400-550/2/65-80
- MAF 100/4/65-80
- GRF 150-200/2/G40H
- GRN 250/2/G40H
- GRN 300-400-550/2/G50H
- GRP 750/2/G50H
- APF 150-200/2/G40H
- APN 250/2/G40H
- APN 300-400-550/2/G50H
- APP 750-1000/2/G50H

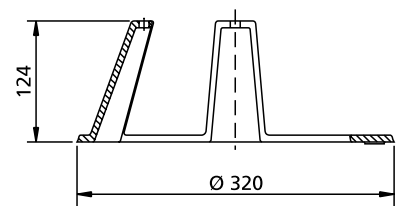

9024.007



Cast iron 4 spoke base plate for free installation. Suitable for the following models:

- DGF 100/4/65-80
- DGN 200-300-400/4/65-80-100
- DGN 150/6/65-80-100
- DGN 250/6/80-100-150
- DRF 100/4/65-80-100
- DRN 400-550/2/100
- DRN 200-300-400/4/80-100
- DRN 150/6/80-100
- DRN 250/6/100-150
- MAN 400-550/2/100
- MAN 200-300-400/4/80-100
- MAN 150/6/80-100
- MAN 250/6/80-100-150
- MAF 100/4/100
- SMP 400/4/100-150
- SMP 750-1000/4/100-150
- SMP 1500-2000/4/150
- SBP 750-1000/4/150

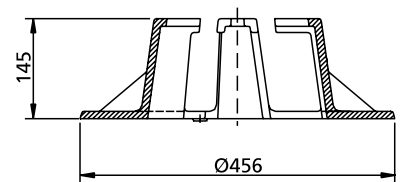

9024.009



Cast iron 4 spoke base plate for free installation. Suitable for the following models:

- SMN 3000/4/150-200-250
- SMP 750/6/200-250
- SMP 2000/4/200-250
- SBN 3000/4/150-200-250
- SBN 4000/4/150-200-250
- SBN 5000/4/150-200-250
- SBN 2500/6/150-250-300
- SBN 3000/6/250-300
- SBP 1000-1500/6/200-250

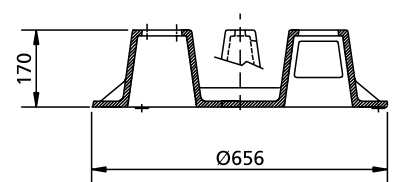

GALVANISED IRON BASE PLATES

9024.008



Hot-galvanized steel base plate. Suitable for the following models:

- GRN 300-400/4/80-100

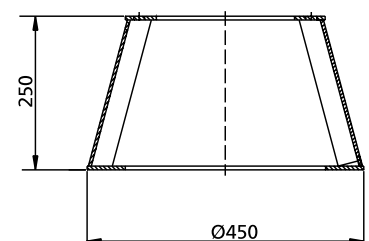

4.2 FLUSHING VALVE

Sediments often form in lifting stations which collect the wastewater from drain systems. Over time, the solids tend to compact on the bottom and sides of the tank, reducing its volume, and when they break away they very often foul the pump.

A specific operation, involving a lengthy, expensive system shutdown, is therefore necessary to remove them.

The FLX flushing valve is an accessory that generates an adjustable-direction jet of water inside the pit to move the solids around and prevent sediment from accumulating on the bottom. Constructed in cast iron, it can be installed directly on the pump casing by means of a threaded coupling. It operates on the Venturi principle and does not require an electricity supply. A regulator allows the valve closure time to be set between 10 and 400 seconds, depending on pit size, pump power or the amount of sediment to be shifted.

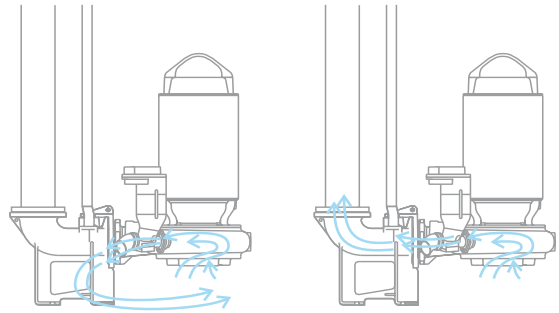

The heart of the FLX flushing valve is an innovative patented system comprising 2 rubber balls joined together by a flexible diaphragm. When the pump starts up, the valve is open and the liquid in the pit is drawn into the pump and circulated through the pit, to place all the solid sediments in suspension (phase 1).

After a time set by the user by means of a regulator, the vacuum created in the valve body recalls a rubber diaphragm, which pushes the two balls downward to shut off the flow (phase 2) and allow the water to be conveyed to the delivery outlet before the solid is deposited on the bottom again.

When the pump stops, the vacuum inside the valve raises the diaphragm (phase 3) and the balls (phase 4), which open the valve ready for the next cycle.

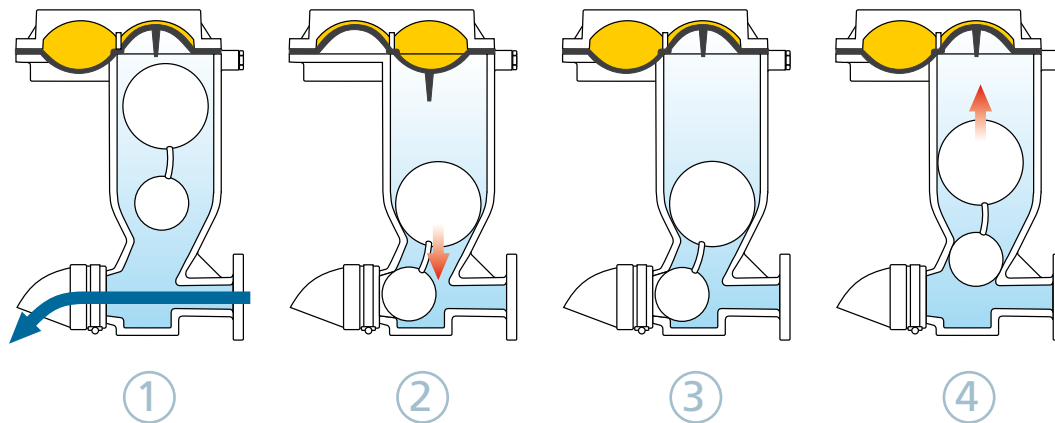

The FLX flushing valve is a Zenit patent.

This is what happens

The formation of a solid deposit in the tank (left) has made it necessary to install flushing valves to generate turbulence inside the tank and help to keep the solids in suspension (right).



FLX

Flushing valve

General characteristics

- Cast iron body
- Hard-wearing rubber balls
- Connection to system by means of a diamond-shaped flange compatible with competitor models, or with a GAS 1 1/2" threaded connection
- Closure time setting from 10 to 400 seconds
- Adjustable-direction jet

Advantages

- Lower noise level
- No maintenance thanks to the rubber balls

Construction materials

body material	Cast iron GJL-250
membrane material	Nitril rubber
ball material	SBR+polyurethane
liquid	Glycol in 10% solution

Connected pump requirements

Total head	5 ÷ 20 m
delivery rate	100÷17000 l/min
liquid temperature	0÷40°C

Connected pump working point

maximum permitted delivery rate range	750÷17000 l/min
pump minimum weight	70 kg

Modified valves can be supplied for applications outside the permitted working range.
 N.B.: the operating limits refer to the valve connected to the pump volute.

Overall dimensions and weights

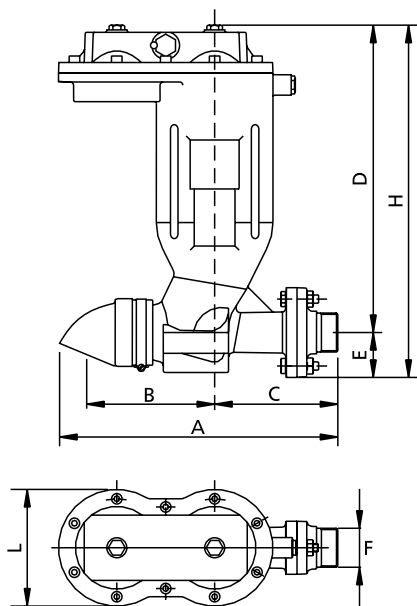

	A	B	C	D	E	F	H	L	kg
FLX - G40	341	157	151	337	55	1 1/2"	432	143	16

Measurements in mm



A year after installation, this is the condition of a metal ball of the type normally used in competitor flushing valves (left) and the rubber ball used in the Zenit FLX.

4.3 CHECK VALVES AND GATE VALVES

Zenit check valves, certified EN 12050-4 annex ZA standard EN 12050-4, are designed for use even with soiled liquids and provide full guarantees of operation even under heavy-duty working conditions.

The sinking ball system ensures a free passage since, at maximum opening, the valve has a completely free main line, greatly reducing pressure drops.

The fact that it can be installed in a horizontal or vertical position provides greater versatility and optimal assembly.

Clapet valves can be used for non abrasive clear wastewaters. Zenit models have a structure and disc made of GJL-250 cast iron and a seat of brass and EPDM rubber. The lever, which allows the mechanism to be moved, is made of GJS 400 cast iron in order to provide maximum reliability. The conformance to international design regulations expedites the installation and makes them compatible with any standard flange.



The knife gate valves, with handwheel control, have various functions and are used as interception units to regulate the flow in a pipeline or to temporarily isolate a section of the plant.

The gate valves have a structure in GJL-250 cast iron inside of which are the mechanisms used to partially or totally block the flow.

This product is set up to receive a servomotor for the remote partial or total opening/closing (without manual intervention).



The Zenit gate valves are made of GJL-250 cast iron, the gate's sliding seat is in brass to ensure maneuverability over time, even after long periods without use.

The flanges meet the UNI standards and ensure that they are perfectly interchangeable.

They are mainly used in civil and industrial wastewater treatment and distribution plants in general.

VAP

Ball check valves

General characteristics

- structure in GJL-250 cast iron with rubber seals included
- sinking ball in NBR rubber
- sealing ensured by rubber on rubber contact
- stainless steel metal fasteners
- epoxy paint resistant to aggressive liquids
- full free passage
- easily removable cover for plant inspection
- can be installed in a horizontal or vertical position

Models

VAP/G32	GAS 1 1/4" thread
VAP/G40	GAS 1 1/2" thread
VAP/G50	GAS 2" thread
VAP/65	DN65 PN10-16 flanged
VAP/80	DN80 PN10-16 flanged
VAP/100	DN100 PN10-16 flanged
VAP/150	DN150 PN10-16 flanged
VAP/200	DN200 PN10- flanged
VAP/250	DN250 PN10- flanged
VAP/300	DN300 PN10- flanged



The entire range of ball valves have "rubber on rubber" coupling (rubber ball; seal on rubber gaskets).

Advantages

- lower noise level
- possibility of easily restoring the coupling between ball and lip closure
- there is no need to purchase commercial gaskets for between the flanges

Operating limits

Ambient temperature and treated liquid: 0 to +40°C
 pH of treated liquid: 6 ÷ 11
 Density of treated liquid: 1 kg/dm³

Contact Zenit if you have requirements that are outside the usage limits

Reference standards

EN 12050-4, EN 12050-2, EN 12050-1, EN 1561, EN ISO 3506-1, EN ISO 3506-2, EN 10025, EN 1092-1, EN ISO 228-1, Directive 89/106/EEC

Overall dimensions and weights

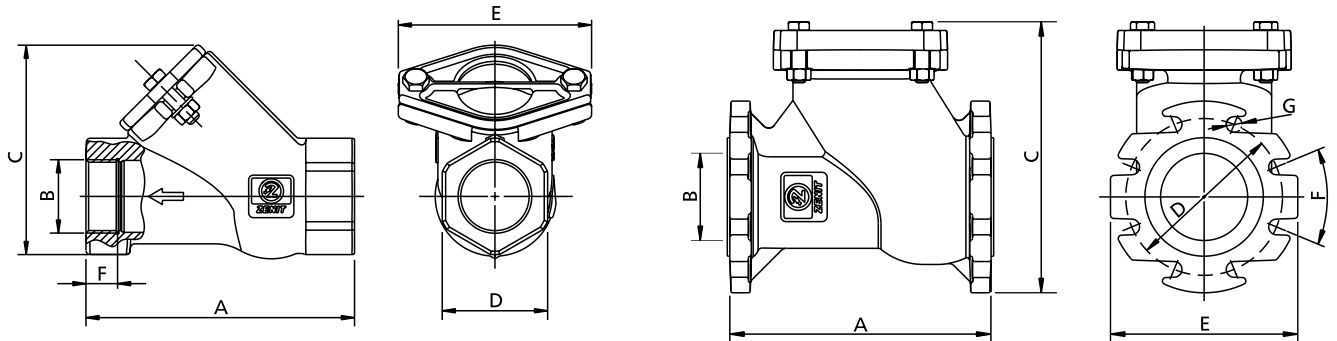

	A	B	C	D	E	F	G	kg	Packaging dimensions		
									A	B	C
VAP/G32	155	1 1/4"	120	60	110	20	-	2	200	135	160
VAP/G40	155	1 1/2"	120	60	110	20	-	1.9	200	135	160
VAP/G50	180	2"	150	72	115	25	-	3	200	135	160

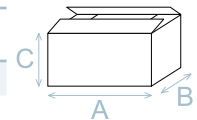

	A	B	C	D	E	F	G	kg	Packaging dimensions		
									A	B	C
VAP/65	240	65	220	145	185	90°	18	11	235	230	190
VAP/80	260	80	255	160	200	45°	18	14	320	280	190
VAP/100	300	100	310	180	220	45°	18	24.5	390	330	235
VAP/150	400	150	425	240	285	45°	22	45	-	-	-
VAP/200	500	200	540	295	340	45°	22	90	-	-	-
VAP/250	600	250	630	350	395	30°	22	163	-	-	-
VAP/300	700	300	680	400	445	30°	22	230	-	-	-

Measurements in mm

The indication PN refers to the flange and not to the maximum operating pressure.



VAC

Clapet check valves

General characteristics

- structure and head in GJL-250 cast iron
- seal in EPDM rubber
- brass seats
- epoxy paint resistant to aggressive liquids
- can be installed in a horizontal or vertical position
- screws can be used for the manual partial opening of the valve. This option is particularly useful for the draining of the pipeline upstream of the valve during any maintenance interventions



Models

VAC/100	DN100 PN 10-16 flange
VAC/150	DN150 PN 10-16 flange
VAC/200	DN200 PN 10 flange
VAC/250	DN250 PN 10 flange
VAC/300	DN300 PN 10 flange

Operating limits

Operating temperature Min 0°C - Max +50°C

Reference standards

Project standard	EN 1074-3
Gauge	EN 558-1
Flange	EN 1092-2
Testing	EN 12266

Overall dimensions and weights

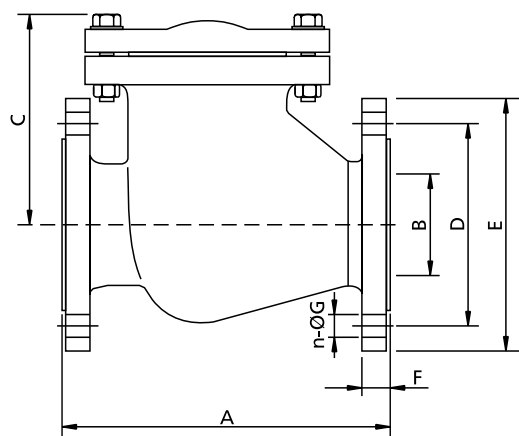

	A	B	C	D	E	F	n-ØG	kg
VAC/100	300	100	175	180	220	25	8-18	32
VAC/150	400	150	230	240	285	25	8-18	71.5
VAC/200	500	200	250	295	340	25	8-23	95
VAC/250	600	250	310	350	395	30	12-23	139
VAC/300	700	300	320	400	445	30	12-23	286

Measurements in mm

Contact the Customer Service department for the availability of larger diameter products

SRP

Knife gate valves with handwheel control

General characteristics

- structure in GJL-250 cast iron
- stainless steel shaft with O-ring seal
- bronze seats
- epoxy paint
- can be installed in a horizontal or vertical position
- integral free passage when fully open

Models

SRP/50	DN50 PN10-16 flange – installation height 150 mm
SRP/65	DN65 PN10-16 flange – installation height 170 mm
SRP/80	DN80 PN10-16 flange – installation height 180 mm
SRP/100	DN100 PN10-16 flange – installation height 190 mm
SRP/150	DN150 PN10-16 flange – installation height 210 mm
SRP/200	DN200 PN10 flange – installation height 230 mm
SRP/250	DN250 PN10 flange – installation height 250 mm
SRP/300	DN300 PN10 flange – installation height 270 mm
SRP/350	DN350 PN10 flange – installation height 290 mm



Operating limits

Operating temperature 0 - 90°C

Reference standards

Project standard	EN 1171, EN 1074-2
Gauge	EN 558-1 series 14
Flange	EN 1092-2
Testing	EN 12266

Overall dimensions and weights

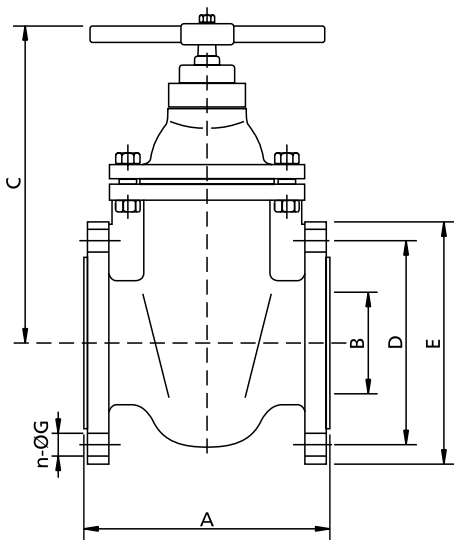

	A	B	C	D	E	n-ØG	kg
SRP/50	150	50	290	125	165	4-18	11.8
SRP/65	170	65	325	145	185	4-18	15
SRP/80	180	80	360	160	200	8-18	19.2
SRP/100	190	100	380	180	220	8-18	26.4
SRP/150	210	150	490	240	285	8-23	50
SRP/200	230	200	580	295	340	8-23	78
SRP/250	250	250	710	350	395	12-23	142
SRP/300	270	300	770	400	445	12-23	179
SRP/350	290	350	830	460	505	16-23	220

Measurements in mm

4.4 BEND UNIONS

Zenit bend unions are made from GFL-250 cast iron or galvanized steel and have UNI standard flanges to guarantee complete interchangeability.

There are 2 types of bend unions: inlet and outlet.

KBC inlet bend unions + the hydraulic connection to be made to pumps for dry chamber installations. This accessory was created to sustain the weight of the pump and so that it could be fastened onto the support base.

The **KCR outlet unions** are designed to be coupled to the pump's delivery port or inside the plants, both of which provide a 90° direction change. They may be flange-flange or flange-thread type, for maximum versatility. They provide full free passage. Another advantage is the reduced curvature radius, which allows a lower overall dimension to be obtained with respect to all the other accessories on the market. Depending on the models, they can be made of GJL-250 cast iron, galvanized steel or stainless steel.



KBC Inlet bends

General characteristics

- structure made of GJL-250 cast iron or galvanized steel
- epoxy paint
- seal in NBR

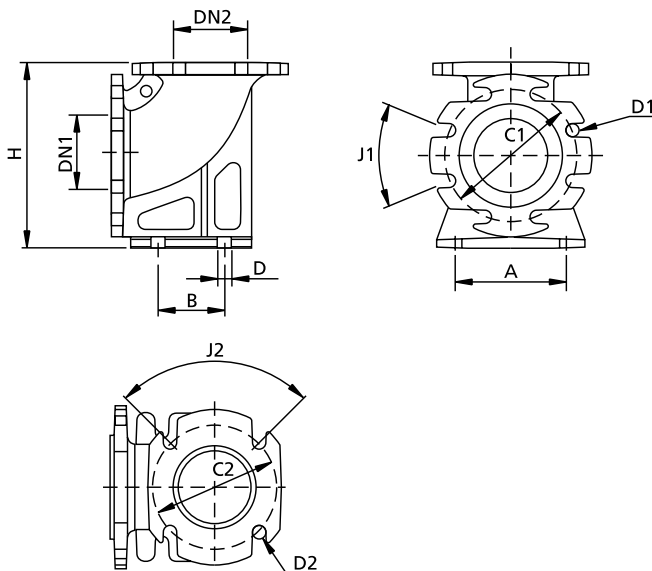

Packaging dimension

	A	B	D
KBC 50/50	385	225	245
KBC 65/65	385	225	245
KBC 80/80	385	225	245
KBC 100/100	475	285	235

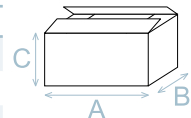

	A	B	D	H	DN1	C1	D1	J1	DN2	C2	D2	J2	kg
KBC 50/50	120	90	17	220	50	125	18	90	50	125	18	90	8
KBC 65/65	130	90	17	245	65	145	18	90	65	130	14	90	10
KBC 80/80	150	90	18	240	80	160	18	90	80	150	18	90	12
KBC 100/100	150	90	18	255	100	180	18	45	100	170	18	90	13.5
KBC 200/150	240	150	18	460	200	295	22	45	150	225	18	45	42
KBC 250/200	290	210	18	530	250	350	22	30	200	280	18	45	64.5

Measurements in mm

KCR

Outlet bends

MALE-FEMALE THREAD (GAS 2")

- structure in stainless steel

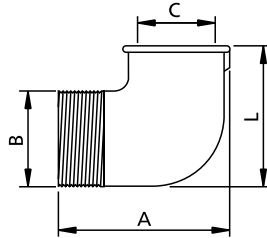

	A	B	C	L	kg	Packaging dimensions		
						A	B	C
KCR G50/G50	90	G 2"	G 2"	90	0.7	230	130	180

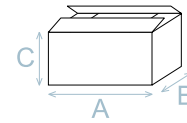

Measurements in mm

FLANGE-THREAD (DN80-DN100)

- structure in GJL-250 cast iron
- epoxy paint
- seal in NBR

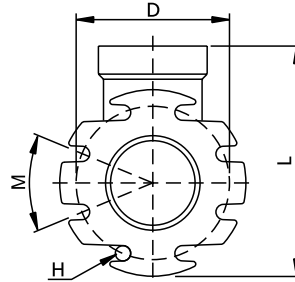
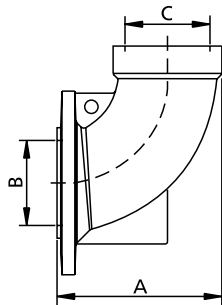

	A	B	C	D	H	L	M	kg	Packaging dimensions		
									A	B	C
KCR 80/G80	180	80	G 3"	160	18	250	90	7.5	385	225	245
KCR 100/G100	190	100	G 4"	180	18	270	45	12	385	225	245

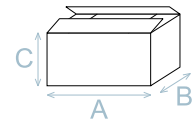

Measurements in mm

FLANGE-FLANGE (DN65 PN10-16÷DN250 PN10)

- structure made of GJL-250 cast iron or galvanized steel
- epoxy paint
- seal in NBR

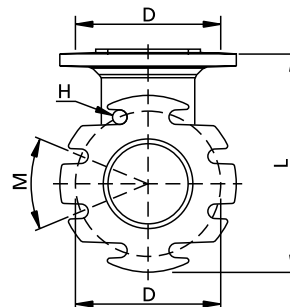
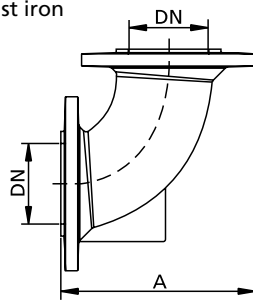

	A	L	DN	D	H	M	kg	Packaging dimensions		
								A	B	C
KCR 50/50	190	190	50	125	18	90°	4	385	225	245
KCR 65/65	220	220	65	145	18	90°	7	385	225	245
KCR 80/80	224	224	80	160	22	90°	8.8	385	225	245
KCR 100/100	273	273	100	180	18	45°	11	385	225	245
KCR 150/150	370	370	150	240	22	45°	19.5	580	310	310
KCR 200/200	475	475	200	295	22	45°	33.5	725	445	415
KCR 250/250	580	580	250	350	22	30°	45	-	-	-

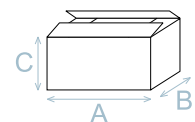

Measurements in mm

4.5 FLANGES AND CHAINS

KFL Flange

Flange in GJL-250 cast iron painted with epoxy coating

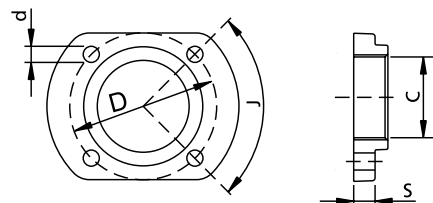

Cast iron flange to transform the delivery port from GAS 1 1/2" to GAS 2". Designed to be coupled to electric pumps with DN32 PN6 outlet flange.

	C	d	D	J	S	kg
KFL 32/G50	G 2"	M12	90	90	15	0.75

Measurements in mm

Threaded and welded flanges PN6 and PN 10-16 in accordance with standard EN 1092-1

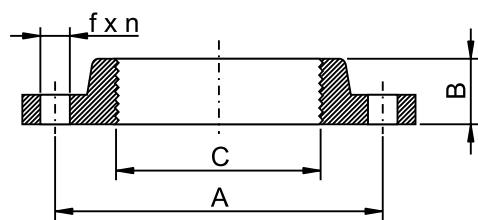

	A	B	C	f	n	kg
KFL / G50 PN16	125	30	2"	18	4	2.8
KFL / G65 PN6	130	30	2 1/2"	14	4	2.1
KFL / G65 PN16	145	30	2 1/2"	18	4	3.5
KFL / G80 PN6	150	35	3"	18	4	3.2
KFL / G80 PN16	160	35	3"	18	8	4.2
KFL / G100 PN6	170	40	4"	18	4	3.5
KFL / G100 PN 16	180	40	4"	18	8	4.9

Measurements in mm

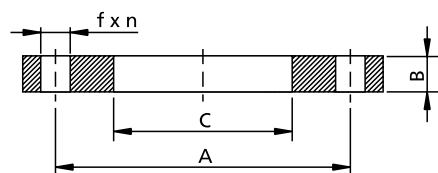

	A	B	C	f	n	kg
KFL / 100 PN10	180	20	108	18	8	4.6
KFL / 150 PN10	240	25	159	22	8	7.6
KFL / 200 PN10	295	25	216	22	8	10.0
KFL / 250 PN10	350	30	267	22	12	13.4
KFL / 300 PN10	400	30	318	22	12	14.8

Measurements in mm

KAT Chains

Stainless steel or galvanized steel chains. Suitable for moving pumps from tanks and wells.

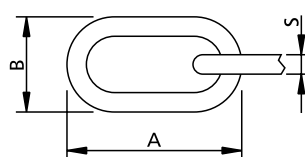

material	dimensions			weight (gr/m)	max load (*) (kg)
	D	d	s		
AISI 316	33	19.5	5	482	325
AISI 316	51	30.5	8	1250	700
Fe 430	51	30.5	8	1205	650
Fe 430	71.5	44.5	12	2895	1500

(*) Uncertified approximate loads

Measurements in mm